

## Corner Beads: CB15.3

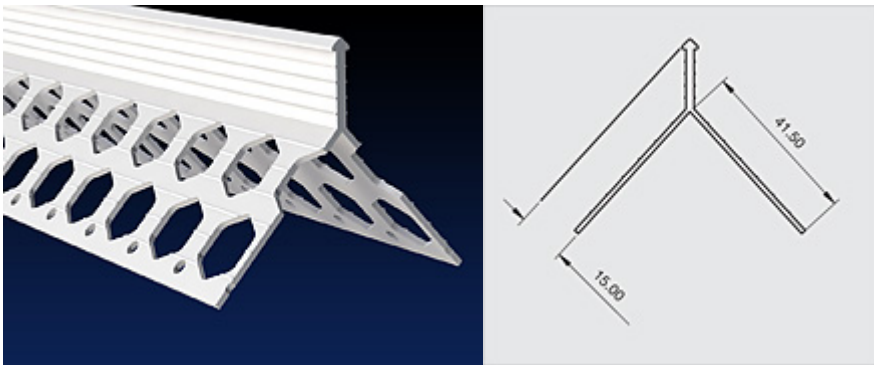

Locally manufactured from recycled plastic, Renderplas PVCu corner beads / angle beads are designed for function and speed on all external and internal rendering and plastering applications. Discreet but strong, all beading gives a perfect finish to through colour render and is equally suitable for sand and cement

### Performance: design data

<b>Affiliations</b>	The National Insulation Association NBS Plus	<b>Fire</b>	Class 1Y. Combustible within fire source, self extinguishing upon removal of flame, will not contribute to the combustion of the system
<b>Applications</b>	All standard rendering and internal plastering applications, external wall insulation systems, timber frame. Provides a straight edge to external corners and reveals	<b>Health and Safety</b>	PVCu beads are safe to handle removing the dangers of cut metal; suitable for prisons and schools
<b>Chemical</b>	Zero chemical reaction with water, sand and cement, acrylic render, water based paint; avoid organic solvents, chlorate bleach, strong acids and alkalis	<b>Heat</b>	Ideal for all habitable climates
<b>Durability</b>	Impact resistant; dissipates shock waves; outlasts metal; cleaned or painted in same way as render	<b>Guarantees</b>	Fit for purpose for the lifetime of the render and at least 25 years
<b>Economics</b>	PVC beads are a fraction of the price of stainless steel; added value over galvanized steel as PVC beads are guaranteed not to stain or corrode and can reduce installation time. Reduction of impact damage	<b>Mechanics</b>	Meets equivalent British Standard for metal beads and lath BS EN 13658-2:2005
<b>Environment</b>	Locally manufactured; high recycled content; fully recyclable; low Ecopoint score of 0.004/kg delivered	<b>Pollution</b>	Ecologically benign; non-hazardous in water; non-hazardous if ingested; does not release substances into the atmosphere
		<b>Strength</b>	PVCu beads offer sufficient strength for these applications
		<b>Weather</b>	Not affected by weather and should be specified in all regions of high moisture or high salt

### Specification: standard data

<b>Type</b>	CB15.3	<b>Weight (kg/100m)</b>	19.1
<b>Authority</b>	BBA certified; manufactured to ISO 9001:2000; complies with BS EN 13914-1&2:2016 and BS EN 13658-2:2005; fire tested to BS 476; complies with REACH	<b>Stock Colours</b>	White
<b>Brand Names</b>	Renderplas	<b>Length</b>	3.0m
<b>Description</b>	15mm PVCu Corner Beads (Angle Beads)	<b>Packaging</b>	25 lengths in triwall fibreboard box
<b>Composition</b>	Exterior grade impact resistant UV stable unplasticised PVCu	<b>Format</b>	Cut lengths
<b>Dimensions (mm)</b>	4mm visible aris; 40mm wing	<b>Price (£/100m)</b>	
<b>Depth (mm)</b>	14-17mm render depth	<b>Recycled Content %</b>	100%
		<b>Light</b>	UV stable; any discoloration is uniform over a single facade and within industry standards

### Site works

<b>Installation</b>	Standard industry practice and tools can be used. Large irregularities in the substrate should be dubbed out and allowed to set hard prior to application. Cut to length with tin snips or fine tooth saw. Fixing with a continuous line of adhesive mortar is preferred on blockwork, or alternatively a bed of render. Non-corrosive mechanical fixings can be used as well but are not required. With external wall insulation, non-corrosive fixings alone are sufficient.	<b>Storage</b>	Store vertically out of direct sunlight or extreme temperatures. Can be stored flat if supported along entire length
		<b>Supply</b>	Ex-stock next day delivery to site through extensive supply chain or direct from <a href="http://www.renderplas.co.uk">www.renderplas.co.uk</a>