

Corner Beads: CB10.3

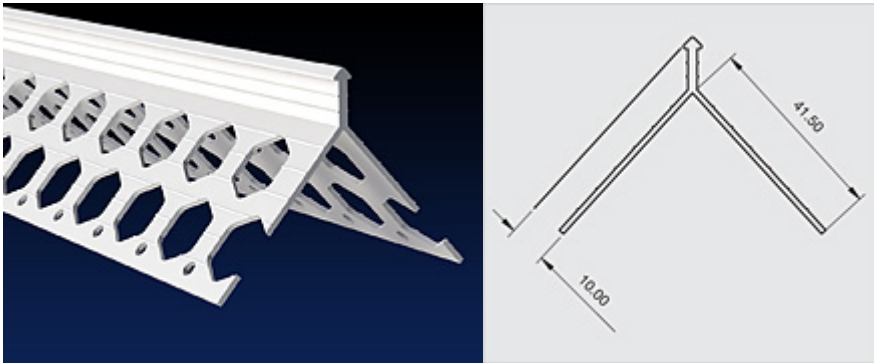

Locally manufactured from recycled plastic, Renderplas PVCu corner beads / angle beads are designed for function and speed on all external and internal rendering and plastering applications. Discreet but strong, all beading gives a perfect finish to through colour render and is equally suitable for sand and cement

Performance: design data

Affiliations	The National Insulation Association NBS Plus	Fire	Class 1Y. Combustible within fire source, self extinguishing upon removal of flame, will not contribute to the combustion of the system
Applications	All standard rendering and internal plastering applications, external wall insulation systems, timber frame. Provides a straight edge to external corners and reveals	Health and Safety	PVCu beads are safe to handle removing the dangers of cut metal; suitable for prisons and schools
Chemical	Zero chemical reaction with water, sand and cement, acrylic render, water based paint; avoid organic solvents, chlorate bleach, strong acids and alkalis	Heat	Ideal for all habitable climates
Durability	Impact resistant; dissipates shock waves; outlasts metal; cleaned or painted in same way as render	Guarantees	Fit for purpose for the lifetime of the render and at least 25 years
Economics	PVC beads are a fraction of the price of stainless steel; added value over galvanized steel as PVC beads are guaranteed not to stain or corrode and can reduce installation time. Reduction of impact damage	Mechanics	Meets equivalent British Standard for metal beads and lath BS EN 13658-2:2005
Environment	Locally manufactured; high recycled content; fully recyclable; low Ecopoint score of 0.004/kg delivered	Pollution	Ecologically benign; non-hazardous in water; non-hazardous if ingested; does not release substances into the atmosphere
		Strength	PVCu beads offer sufficient strength for these applications
		Weather	Not affected by weather and should be specified in all regions of high moisture or high salt

Specification: standard data

Type	CB10.3	Weight (kg/100m)	16.3
Authority	BBA certified; manufactured to ISO 9001:2000; complies with BS EN 13914-1&2:2016 and BS EN 13658-2:2005; fire tested to BS 476; complies with REACH	Stock Colours	White
Brand Names	Renderplas	Length	3.0m
Description	10mm PVCu Corner Beads (Angle Beads)	Packaging	25 lengths in triwall fibreboard box
Composition	Exterior grade impact resistant UV stable unplasticised PVCu	Format	Cut lengths
Dimensions (mm)	4mm visible aris; 40mm wing	Price (£/100m)	
Depth (mm)	10-12mm render depth	Recycled Content %	100%
		Light	UV stable; any discoloration is uniform over a single facade and within industry standards

Site works

Installation	Standard industry practice and tools can be used. Large irregularities in the substrate should be dubbed out and allowed to set hard prior to application. Cut to length with tin snips or fine tooth saw. Fixing with a continuous line of adhesive mortar is preferred on blockwork, or alternatively a bed of render. Non-corrosive mechanical fixings can be used as well but are not required. With external wall insulation, non-corrosive fixings alone are sufficient	Storage	Store vertically out of direct sunlight or extreme temperatures. Can be stored flat if supported along entire length
		Supply	Ex-stock next day delivery to site through extensive supply chain or direct from www.renderplas.co.uk